

DETAIL: BELLY BAR
(NOT TO SCALE)

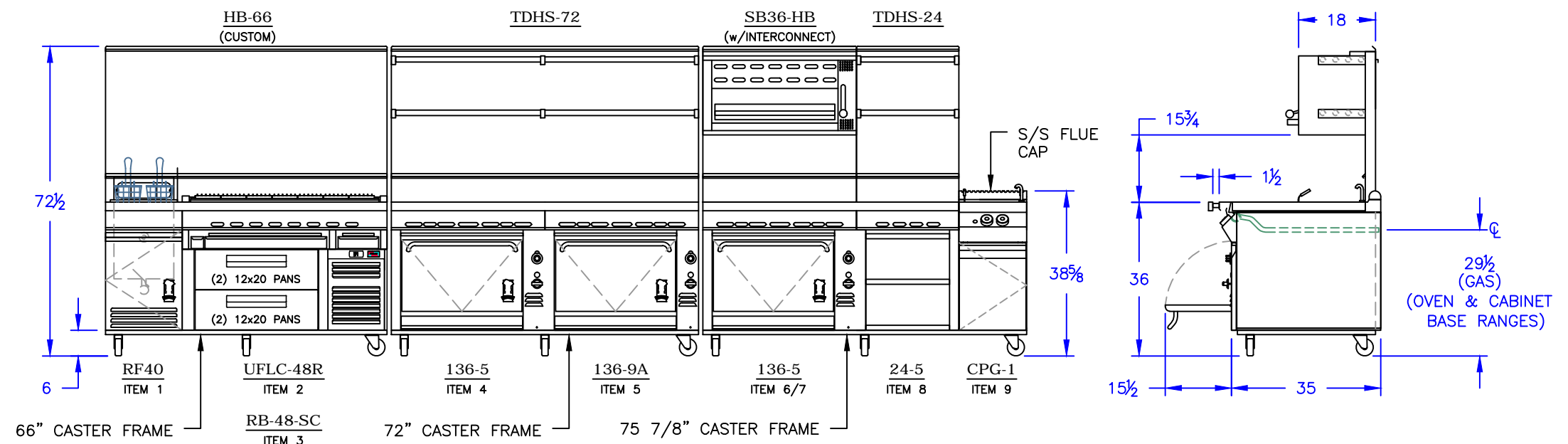
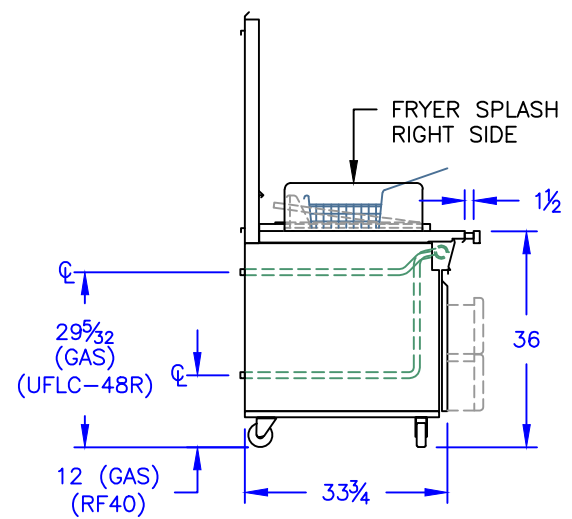
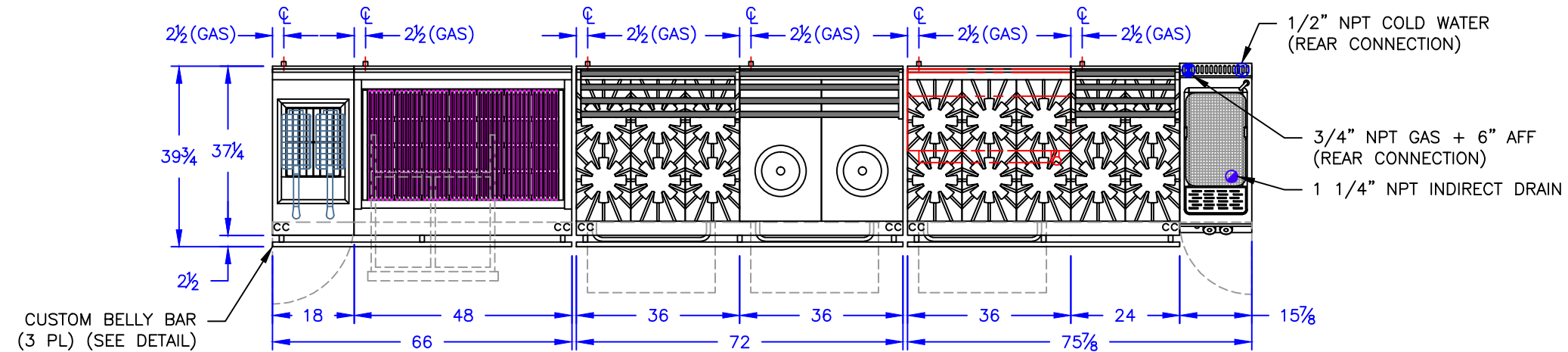

UTILITY DATA							
MODEL	ITEM	QTY.	GAS SIZE	B.T.U./HR.	ELECTRIC	WATER	DRAIN
RF40	1	1	1" NPT	110,000			
UFLC-48R	2	1	1" NPT	152,000			
RB-48-SC	3	1			1/3 HP, 8.0 AMPS, 120/60/1, 6' CORD w/NEMA 5-15P		
BATTERY TOTAL: GAS; NATURAL @ 6" W.C., 262,000 BTU/HR. ELECTRIC: 120/60/1, 8.0 AMPS							
136-5	4	1	1" NPT	220,000			
136-9A	5	1	1" NPT	110,000			
BATTERY TOTAL: GAS; NATURAL @ 6" W.C., 330,000 BTU/HR							
136-5	6	1	1" NPT	220,000			
SB36-HB	7	1		32,000			
24-5	8	1	1" NPT	120,000			
CPG-1	9		3/4" NPT	60,000		1/2" NPT	1 1/4" NPT
BATTERY TOTAL: GAS; NATURAL @ 6" W.C., 432,000 BTU/HR							
EQUIPMENT TOTAL: GAS; NATURAL @ 6" W.C., 1,024,000 BTU/HR. ELECTRIC: 120/60/1, 8.0 AMPS							

NOTES:
PANS ARE NOT INCLUDED WITH REFRIGERATED BASE.
AFF = ABOVE FINISHED FLOOR.

PRODUCTION SUBMITTAL

CUSTOMER APPROVAL	
<input type="checkbox"/> APPROVED AS SUBMITTED	<input type="checkbox"/> REVISE AND RESUBMIT
SIGNATURE: _____	DATE: _____
PRINT NAME: _____	
SALES APPROVAL	
SIGNATURE: _____	DATE: _____



PROPRIETARY RIGHTS: THIS DOCUMENT CONTAINS INFORMATION DEEMED PROPRIETARY TO THE MONTAGUE Co. AND IS TO BE USED ONLY FOR THE PURPOSE FOR WHICH THEY ARE SUBMITTED AND SHALL NOT BE COPIED IN WHOLE OR IN PART WITHOUT EXPRESS WRITTEN PERMISSION OBTAINED FROM THE MONTAGUE COMPANY.

DIMENSIONS ARE IN INCHES
TOLERANCES:
DECIMALS ± 0.020
FRACTIONS: ±1/32
DEGREES: ±

UNLESS OTHERWISE SPECIFIED

THE MONTAGUE COMPANY			
1830 STEARMAN AVENUE HAYWARD, CA 94545			
SALES DWG. - BATTERY			
MIA'S RESTAURANT - DELRAY BEACH, FL			
SCALE	3/8"=1'-0"	DRAWN	CWB
DATE	8-24-16	APPROVED	BL
SHEET	1 OF 1	DRAWING No.	65186-9
		REV	0